

STM HPFU

Direct current electronic drivers
Alimentatori elettronici in corrente continua

Made in Italy 



Single current drivers - Not dimmable
Alimentatori corrente singola - Non regolabili

constant CURRENT constant VOLTAGE

RIPPLE FREE

Pst LM ≤ 1
SVM ≤ 0,4



Rated Voltage
Tensione Nominale
100 ÷ 127 V⁽²⁾
100 ÷ 240 V

Frequency
Frequenza
50-60 Hz

AC Operation range
Tensione di utilizzo AC
90 ÷ 264 V

DC Operation range
Tensione di utilizzo DC
(see page info15)
176 ÷ 275 V

Power - Potenza
1 ÷ 10 W

iTHD
≥ 40%⁽¹⁾

Output current ripple
≤ 3%⁽¹⁾

Standards compliance
CSA-C22.2 n° 250.13
EN 55015
EN 61000-3-2
EN 61000-3-3
EN 61347-1
EN 61347-2-13
EN 61547
UL 8750

Max. pcs for CB B16A
(see page info17)
50 pcs

In rush current
20A 170µsec

Article Articolo	Code Codice	P out W	V out DC ⁽¹⁾	I out DC	U out V	ta °C	tc °C	λ max. Power Factor	η max. Efficiency ⁽¹⁾
STM 6W 150mA HPFU ⁽⁴⁾	127714	6	2...36	150 mA cost.	39	-20...+55	80	0,88 C	> 79 %
STM 9W 250mA HPFU	127719	6 ⁽²⁾ /9	2...36	250 mA cost.	39	-20...+55	80	0,88 C	> 79 %
STM 8W 350mA HPFU	127715	6 ⁽²⁾ /8	2...23	350 mA cost.	24	-20...+55 ⁽²⁾ /60	80	0,87 C	> 78 %
STM 10W 350mA HPFU	127716	6 ⁽²⁾ /10	2...30	350 mA cost.	32	-20...+55	80	0,88 C	> 79 %
STM 6W 500mA HPFU	127717	6	2...12,6	500 mA cost.	13	-25...+50 ⁽²⁾ /55	75	0,8 (0,9 ⁽²⁾) C	> 72 %
STM 8W 700mA HPFU ⁽³⁾	127718	6 ⁽²⁾ /8	2...12	700 mA cost.	13	-20...+45	80	0,87 C	> 77 %

⁽¹⁾ Referred to V_{in} = 230 V, 100% load - Riferito a V_{in} = 230 V, carico 100%

⁽²⁾ Without UL - Senza UL

⁽³⁾ Without approval - Senza certificazioni

⁽⁴⁾ Without approval - Senza certificazioni

Light output level in DC operation: Factory default 100% EoFi=1
Livello di emissione luminosa in funzionamento DC: Impostazioni di fabbrica 100% EoFi=1

BUILT-IN SCREW FIXING

Weight - Peso: gr. 35 / 1,23 oz.
Pcs - Pezzi 90

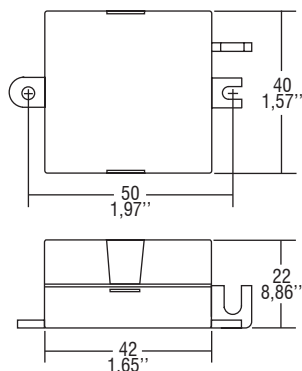

Wiring diagram - Schema di collegamento

(Max. LED distance on page info8 - Massima distanza LED a pagina info8)



Features

- Driver for built-in use.
- Input and output terminal blocks on the same side.
- Single terminal at the primary and secondary circuit (wire cross-section up to 2,5 mm² / AWG13).
- Ultra compact size.
- It can be used for lighting equipment in protection class I and II.
- Driver can be secured with slot for screws.
- Protections:
 - against overheating and short circuits;
 - against mains voltage spikes;
 - against overloads.
- Current regulation -8 %... +5 % including temperature variations.

Caratteristiche

- Alimentatore da incorporare.
- Morsetti di entrata e uscita sullo stesso lato.
- Singolo morsetto su primario e secondario (sezione cavo fino a 2,5 mm² / AWG13).
- Dimensioni molto ridotte e compatte.
- Utilizzabile per apparecchi di illuminazione in classe di protezione I e II.
- Fissaggio dell'alimentatore tramite asole per viti.
- Protezioni:
 - termica e cortocircuito;
 - contro le extra-tensioni di rete;
 - contro i sovraccarichi.
- Corrente regolata -8 %... +5 % incluse variazioni di temperatura.



The data shown are preliminary and may change - I dati riportati sono preliminari e potrebbero subire variazioni