

Junction Box

Terminal Blocks
Dosenklemmen

Topplämmor
Morsetti Volanti



A: Rütistrasse 18, CH-8952 Schlieren

T: +41 (0)44 730 56 56 W: www.elektrogros.ch

F: +41 (0)44 730 77 52 E: shop@elektrogros.ch

EN 60998-2-1 & EN 60335-1

HE25-10
14 410 10

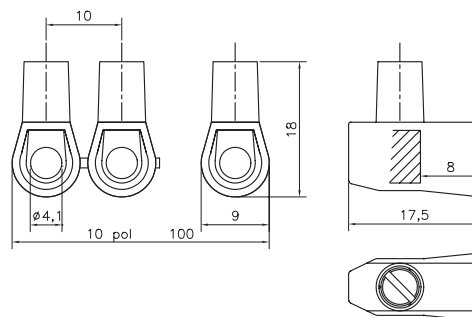
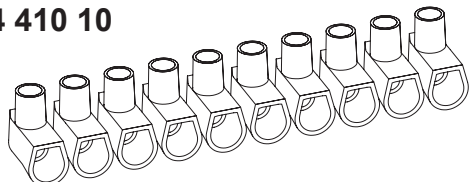

Description	Poles	Insert	Article No.
HE25 10-poles	10	Std.	0251N1050

Torque:
Recommended 0,55 Nm
Max. 0,8 Nm

Stripping Length
Skalning
Abisolierlänge
6 - 7 mm

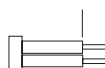

HE25-1
14 408 80
"UBÄTEN®"

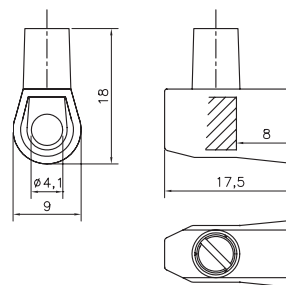
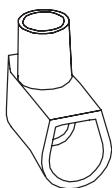

Description	Poles	Insert	Article No.
HE25 1-pole	1	Std.	0251N0150
HE25R 1-pole (Red)	1	Std.	0251N0150R

TECHNICAL DATA

TEKNISKA DATA

TECHNISCHE ANGABEN

Approvals

Godkännanden

Genehmigungen

Voltage	Fixing centres	Cable size	Insert	Screw M3,5	HE25-1	HE25-10
Märkspänning	Delningsmått	Area	Tinned Brass	Steel bluechromated	NEMKO	NEMKO
Nennspannung	Rastermass	Nennquerschnitt	Hylsa	Skruv M3,5	FI	FI
400 V	10 mm	3 x 1,5 & 2 x 2,5 mm²	Mässing förtent	Stål blåkromatiserad	SEMKO	SEMKO
Current	Working temperature	Insulation material	Klemmkörper	Schraube M3,5	INTERTEK	
Märkström	Arbetstemperatur	Isolationsmaterial	Messing verzinkt	Stahl blauchromatieret	CE	CE
Nennstrom	Dauertemperatur	Isoliermaterial			DEMKO	DEMKO
16-25 A	125° C	Polycarbonate				

The junction box terminal blocks are made of glass clear Polycarbonate and can be supplied in strips of 10-poles or as 1-pole. Suitable for use with one or more stranded cables within a junction box or floating connections in light fittings.

Topplämmorna levereras i glasklar plast som 1-polig eller i längder om 10-poler. Lämplig för att koppla en eller fler trådiga ledare i en installationsdosa, apparaters inre ledningssystem eller till belysningsarmaturer.

Die Dosenklemmen aus glasklarem Polycarbonat können sowohl 1-polig wie auch 10-polig geliefert werden. Sehr geeignet für Montage im Apparatebau und für Beleuchtungen um ein oder mehrere Drähte unter einer Schraube zu verbinden.

HE25 meets EN 60335-1 directive for selfextinguishing of plastics (750°C in < 2 sec for domestic applications July 2006.) It also meet EN 60335-1 + A1:2004+A2:2006 = 850°C in < 2 sec.